

EXHEAT

Pre-Engineered Oil Heaters



We make oil heating easy.

Based on years of experience, EXHEAT has designed a range of standard oil heaters that are pre-engineered to ensure we offer advanced delivery times, ease of maintenance and reduced costs.

Improved Lead-Time

All of our pre-engineered oil heaters are based on proven, pre-assembled designs, so you can benefit from advanced delivery times. You can expect your heater in 12 to 14 weeks.

Budget-Friendly

Pre-fabricated heaters based on proven designs means you know you'll be getting the same quality heating at a reduced cost.

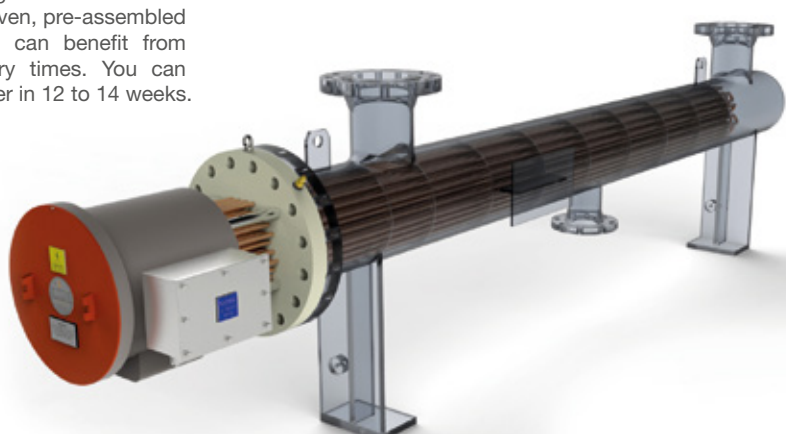

Efficient

Compared to conventional shell and tube heaters, electric heaters virtually convert all electricity used into heat, so heat wastage is reduced.

Controllable

With state-of-the art thyristor control systems, you can be sure your process fluid is heated to just the right temperature.

Ease of Maintenance

Elements are sealed to prevent moisture ingress. They are individually replaceable on site without the need for special tools.

TYPICAL APPLICATIONS



Heat Transfer Oils



Fuel Forwarding



Fuel Separation



Pipelines



Fuel Oils



Crude Oils



Lubricating Oils



Oil Pre-heating

CERTIFICATIONS

EXHEAT's oil heaters are globally certified and hold approvals from North America, Europe and globally through the IECEx scheme for use in potentially explosive atmospheres.



ATEX



INMETRO

CQST

GNEX

CCOE



CE

GOST

PED

EAC



GGTN-K

IGS

SPECIFICATIONS



Design Capacity

- Duty up to 2500kW
- Mass flow up to 330,000kg/hr *
- Watt density up to 2.0 W/cm²
- Design temperature up to: +150°C
- Design pressure up to: 40 barg

*Based on API Mid Continental Crude Oil



Voltage

- Up to 690V (CSA up to 600V)



Design Compliance

- Designs in accordance with ASME VIII, PD5500, EN13445 or AS1210
- Available with optional ASME U 'Code' Stamp, NORSOK compliance, NACE MR0175 and/or PED



Features

- Available in 6" to 36" vessel sizes; long and short models available
- 2 element sensors per stage as standard
- Spare elements installed as standard



Materials of Construction

- Carbon Steel & Stainless Steel
- **Shell:** SA106 Gr. B / SA312 F316/L
- **Nozzle:** SA105N / SA182 F316/L
- **Head & Tee:** SA234 Gr. WPB / SA403 F316/L
- **Plate:** SA516 Gr. 70 / SA240 F316/L

*Elements available in Alloy 800 or Stainless Steel 321

* North America Exd only

** Exd only

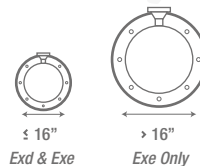

AVAILABLE MODELS

PEOH-FP

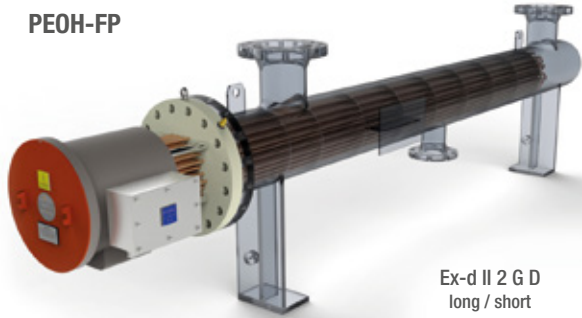

Ex-d II 2 G D long / short

PEOH-ISE

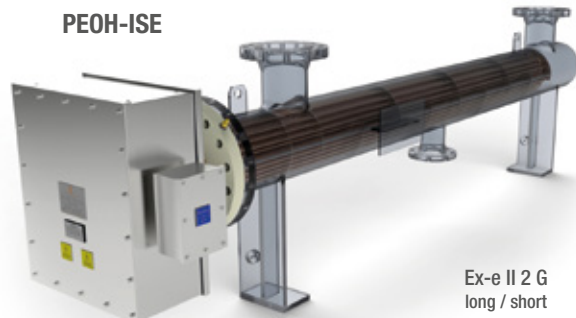

Ex-e II 2 G long / short

CONTACT US

To find out more about EXHEAT and the electric process heaters we design and manufacture, please contact us now for a no obligation quotation.

UK Tel: +44 (0) 1953 886200 | Asia Tel: +65 6496 4618 | Email: sales@exheat.com | Website: www.exheat.com